

Tanaka

Parts Catalog

Hedgetrimmer

Model: THT-200

Part # 12240 3-10-97

THT-200

OPTIONS AND ACCESSORIES

PERFECT MIX® 2-Cycle Engine Oil

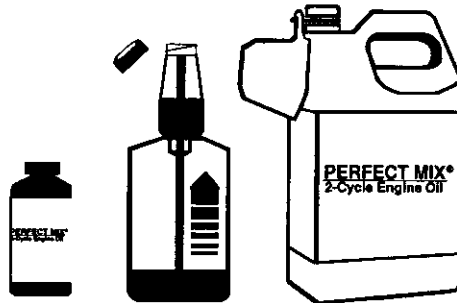

- 700109 2.8 oz. Bottle, 1 Gallon Size (24*)
700108 16 oz. Self-measuring Bottle (24*)
700110 1 Gallon Jug Commercial Size (6*)
* Case Quantity

MANUALS & CATALOGS

19054	Owner's Manual
12240	Parts Catalog

SPECIAL TOOLS

006-29326-000	Flywheel Remover	001-29000-000	Tachometer
009-29323-500	Piston Pin Remover	070-2000W-500	Pressure Tester
037-29476-522	Clutch Remover	070-2000W-501	Carb. Tool Kit

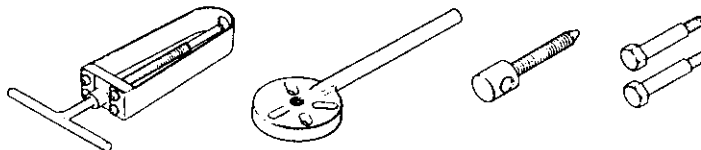

FIG. 1 ENGINE

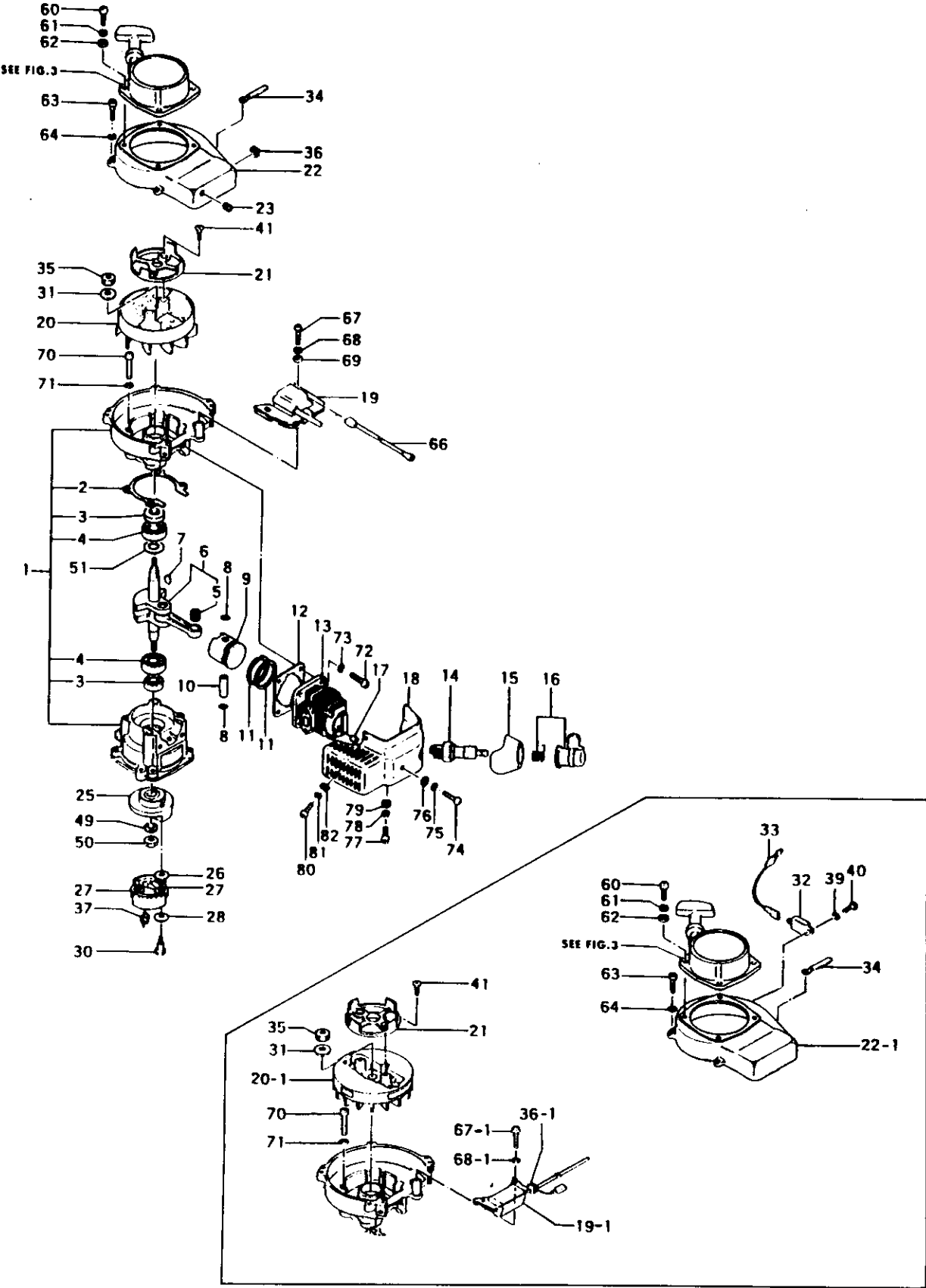

FIGURE 1

THT-200 PARTS LISTING

REF.	PART NO.	PART DESCRIPTION	Q	C	S	SERIAL NO	REMARKS
1	072-0639W-900	CRANKCASE,ASS'Y	1		D	~G076401	Includes bearings, seals & gasket.
1	072-0639W-910	CRANKCASE,ASS'Y	1		D	G076402~	Includes bearings, seals & gasket.
2	090-06000-202	GASKET,CRANKCASE	1		C		
3	999-66122-240	SEAL,OIL,12227	2		A		
4	999-61600-100	BEARING,BALL,#6001	2		B		
5	999-62071-127	BEARING,NEEDLE,F-79	1		C		
6	046-0639W-801	CRANKSHAFT	1		C	~G076401	
6	046-0639W-802	CRANKSHAFT	1		D	G076402~	
7	068-10100-200	KEY,WOODRUFF,3X13X4.5	1		C		
8	039-06100-200	CIRCLIP,PISTON PIN	2		A		
9	031-06320-200	PISTON	1		C		
10	037-06097-200	PIN,PISTON	1		B		
11	041-00000-210	RING,PISTON,LOWER	2		A		
12	017-06091-201	GASKET,CYLINDER	1		B		
13	002-06092-803	CYLINDER	1		C		
14	018-01805-200	PLUG,SPARK	1		B		
15	255-0630G-210	COVER,RUBBER,SPARK PLUG	1		D		
16	157-01570-900	CAP,SPARK PLUG,ASS'Y	1		C		
17	011-0630B-200	COLLAR	1		D		
18	738-0632R-201	PROTECTOR,MUFFLER	1		D		
19-1	167-20745-801	COIL,IGNITION	1		C	~G076401	
19	167-20508-800	COIL,IGNITION	1		B	G076402~	
20-1	155-21718-800	ROTOR,MAGNETO	1		D	~G076401	
20	155-20512-800	ROTOR,MAGNETO	1		D	G076402~	
21	798-0639W-200	PULLEY,STARTER	1		D		
22-1	112-0639W-200	CASE,FAN	1		D	~H271500	
22	112-0639A-210	CASE,FAN	1		D	H271501~	
23	202-01003-201	GROMMET,SECONDARY CORD	1		C		
25	347-0639W-800	FLANGE,CLUTCH	1		D	~G076401	
25	347-0639W-801	FLANGE,CLUTCH	1		D	G076402~	
26	359-02103-200	WASHER,CLUTCH,B	2		B		
27	290-00501-802	SHOE,CLUTCH	2		A	~G076401	
27	290-01620-800	SHOE,CLUTCH	2		A	G076402~	
28	348-0602R-200	WASHER,CLUTCH A	2		B	~D019779	
28	358-02103-200	WASHER,CLUTCH A	2		A	D019780~	
30	357-00601-200	BOLT,STEP,CLUTCH	2		C	~G076401	
30	357-0075T-200	BOLT,STEP	2		A	G076402~	
31	065-00000-200	WASHER,FLYWHEEL	1		D		

* Indicates the part is included in a kit or assembly and is not available individually. Q=Quan. used
C=Interchangeability S=Stocking code: A=Fast moving B=Med. fast C=Med. move D=Slow move
E=N.L.A. F=Superseded or replaced by a new part

FIGURE 1 cont.

THT-200 PARTS LISTING

REF.	PART NO.	PART DESCRIPTION	Q	C	S	SERIAL NO.	REMARKS
32	159-21401-872	IGNITOR,TTI-1F	1		A	~G076401	
33	173-01620-800	CORD,PRIMARY	1		D	~G076401	
34	198-05015-800	CLAMP,CORD	1		C		
35	327-00201-201	NUT,L.H,7	1		D		
36-1	203-0604A-202	GROMMET	1		C	~G076401	
36	203-0639A-200	GROMMET	1		D	G076402~	
37	342-00501-204	SPRING,CLUTCH	1		C	~G076401	
37	342-0630B-200	SPRING,CLUTCH	1		A	G076402~	
39	992-10040-012	WASHER,S,4	1		B		
40	990-11040-081	SCREW,4X8	1		C		
41	990-12060-151	SCREW,FH,6X15	2		D		
49	992-00080-011	WASHER,8	1		D		
50	991-16080-003	NUT,8/L.H	1		D		
51	330-00200-210	SHIM,12.2X19X.10	V		D		Shims are "as needed" to obtain correct c/s side clearance.
51	330-00200-220	SHIM,12.2X19X.15	V		D		
51	330-00200-230	SHIM,12.2X19X.20	V		D		
51	330-00200-240	SHIM,12.2X19X.30	V		D		
60	990-11040-121	SCREW,4X12	4		B		
61	992-10040-012	WASHER,S,4	4		B		
62	992-01040-011	WASHER,4	4		C		
63	990-11050-161	SCREW,5X16	4		B		
64	992-10050-012	WASHER,S,5	4		A		
66	178-0639A-800	CORD,STOP	1		D	G076402~	
67-1	990-11040-181	SCREW,4X18	2		D	~G076401	
67	990-11050-201	SCREW,MX20	2		D	G076402~	
68-1	992-10040-012	WASHER,S,4	2		B	~G076401	
68	992-10050-012	WASHER,S,5	2		A	G076402~	
69	992-00050-011	WASHER,SMALL,5	2		C		
70	990-11050-301	SCREW,5X30	4		C		
71	992-10050-012	WASHER,S,5	4		A		
72	990-11050-201	SCREW,MX20	4		D		
73	992-10050-012	WASHER,S,5	4		A		
74	990-11050-181	SCREW,5X18	1		B		
75	992-10050-012	WASHER,S,5	1		A		
76	992-01050-011	WASHER,5	1		A		
77	990-11050-121	SCREW,5X12	1		A		
78	992-10050-012	WASHER,S,5	1		A		
79	992-01050-011	WASHER,5	1		A		
80	990-11040-121	SCREW,4X12	1		B		
81	992-10040-012	WASHER,S,4	1		B		
82	992-01040-011	WASHER,4	1		C		

FIG.2 ENGINE COMPONENTS

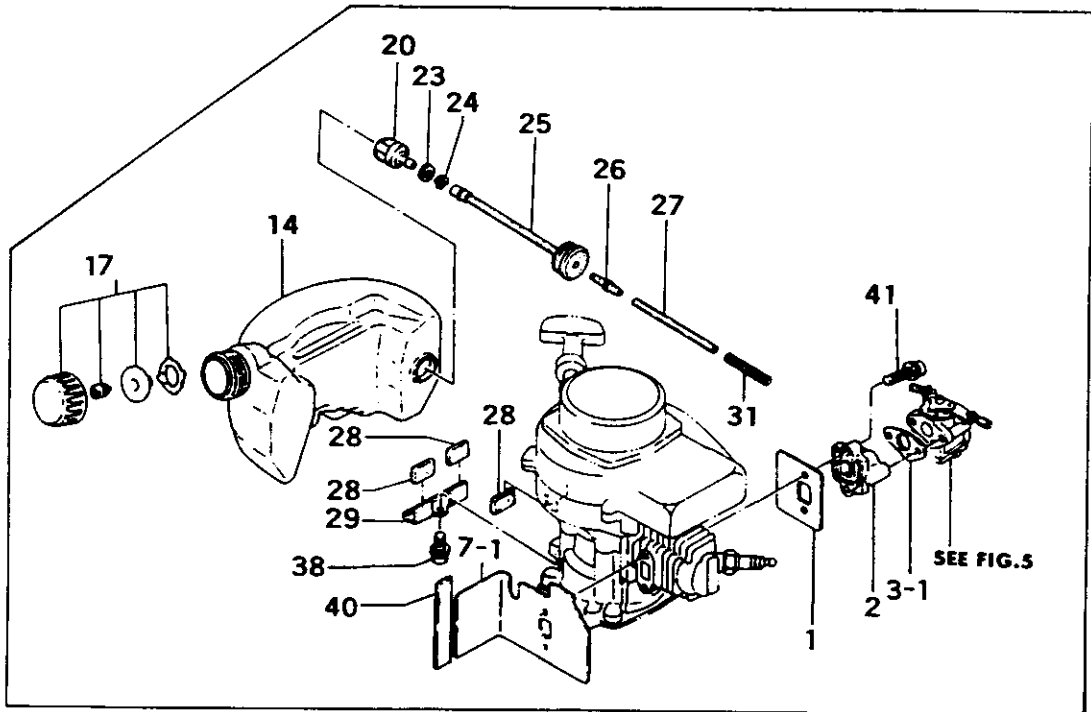
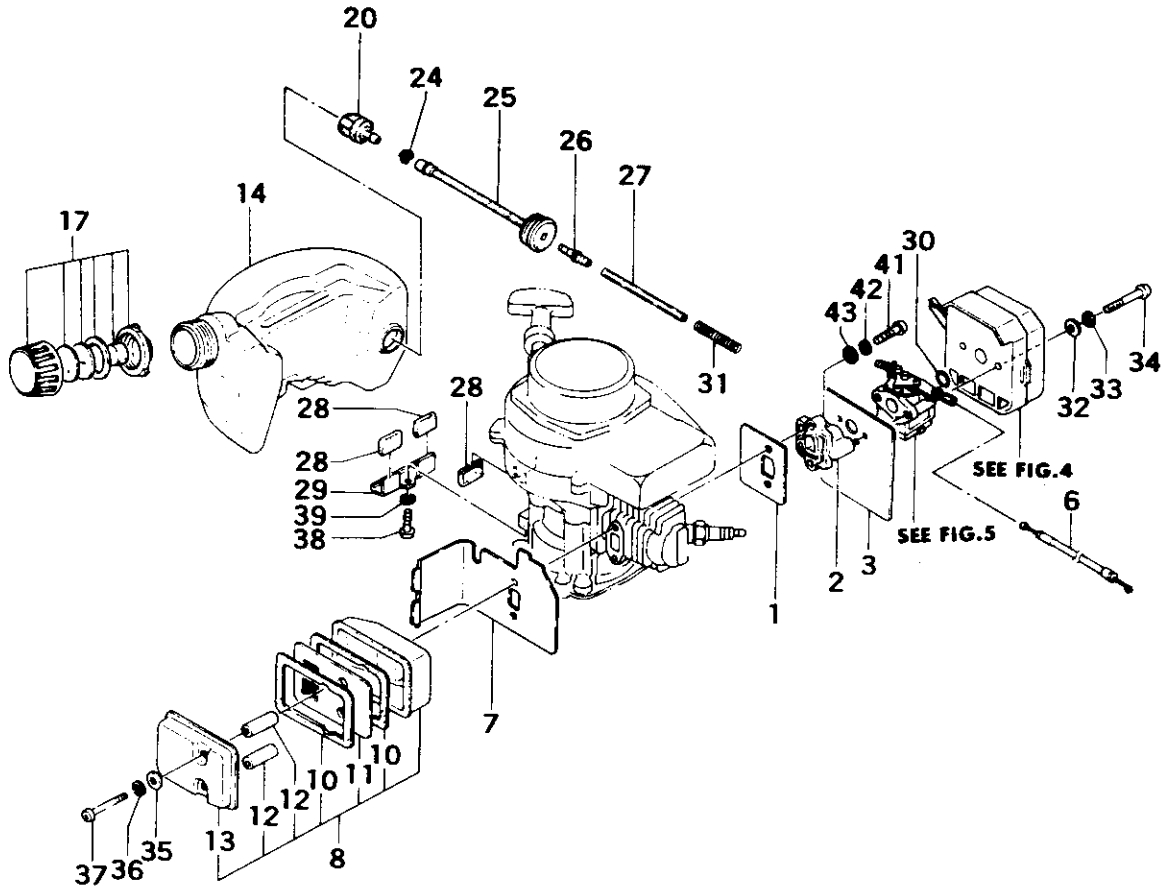

FIGURE 2

THT-200 PARTS LISTING

REF.	PART NO.	PART DESCRIPTION	Q	C	S	SERIAL NO	REMARKS
1	403-0602K-201	GASKET,INLET MANIFOLD	1		A		
2	404-0639W-802	INSULATOR,CARBURETOR	1		A		
3-1	402-0602K-21	GASKET,CARBURETOR	1		C	~G142158	
3	402-0639W-200	SHIELD,HEAT	1		C	G142159~	
6	885-0639W-800	WIRE,THROTTLE	1		C		
7	133-0602K-204	SHIELD,HEAT	1		D		
8	706-0602B-900	MUFFLER,ASS'Y	1		C		
10	739-0602B-200	GASKET,MUFFLER COUPLING	2		B		
11	722-0602B-800	PLATE,MUFFLER PARTITIVE	1		C		
12	740-0602B-201	COLLAR,MUFFLER	2		D		
13	717-0602B-200	BODY,MUFFLER,B	1		D		
14	591-0639W-201	TANK	1		C		
17	595-0650A-90	CAP,TANK	1		A		
20	675-04042-80	FILTER,FUEL	1		A		
23	992-01050-011	WASHER,5	1		A		
24	680-04019-210	CLIP,7	1		B		
25	678-0602W-200	PIPE,RUBBER	1		C		
26	497-32350-200	JOINT,PIPE	1		C		
27	700-03005-110	PIPE,FUEL,3X5X110	1		B		
28	655-06100-200	CUSHION,TANK	4		A		
29	653-06000-200	BRACKET,TANK	1		C		
30	431-0602K-200	GASKET,CLEANER	1		C		
31	702-02004-200	COIL,FUEL PIPE	1		D		
32	992-00050-011	WASHER,SMALL,5	2		C		
33	992-10050-012	WASHER,S,5	2		A		
34	990-11050-451	SCREW,5X45	2		C		
35	992-01050-011	WASHER,5	2		A		
36	992-10050-012	WASHER,S,5	2		A		
37	990-11050-421	SCREW,5X42	2		D		
38	990-11050-141	SCREW,5X14	1		D		
39	992-10050-012	WASHER,S,5	1		A		
40	599-0602K-200	CUSHION	1		D		
41	990-11050-241	SCREW,5X24	2		D		
42	992-10050-012	WASHER,S,5	2		A		
43	992-00050-011	WASHER,SMALL,5	2		C		

* Indicates the part is included in a kit or assembly and is not available individually. Q=Quan. used
C=Interchangeability S=Stocking code: A-Fast moving B=Med. fast C=Med. move D=Slow move
E=N.L.A. F=Superseded or replaced by a new part

FIG.3 RECOIL STARTER

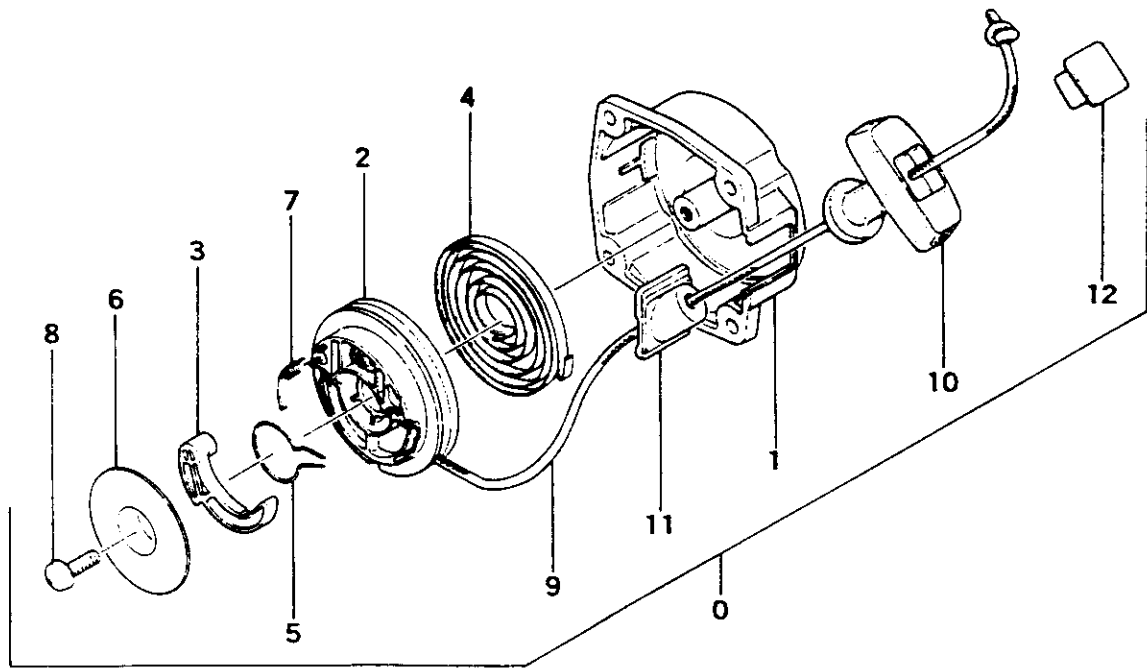

FIGURE 3

THT-200 PARTS LISTING

REF.	PART NO.	PART DESCRIPTION	Q	C	S	SERIAL NO.	REMARKS
0	762-06150-901	STARTER,RECOIL ASS'Y	1		C		
1	772-06150-200	BODY,RECOIL STARTER	1		D		
2	769-01250-200	PULLEY,STARTER	1		C		
3	788-01250-200	PAWL,STARTER	1		D		
4	779-01250-200	SPRING,RECOIL	1		B		
5	836-06092-200	SPRING,FRICTION	1		D		
6	837-06092-200	PLATE,FRICTION	1		C		
7	832-01250-200	SPRING,RETURN	1		D		
8	990-15050-121	SCREW,5X12	1		A		
9	783-0162V-200	ROPE,STARTER,3.5X890	1		D		
10	785-06097-200	HANDLE,STARTER	1		C		
11	780-06150-200	GUIDE,ROPE	1		C		
12	795-0602K-200	CAP,STARTER HANDLE	1		D		

FIG.4 AIR CLEANER

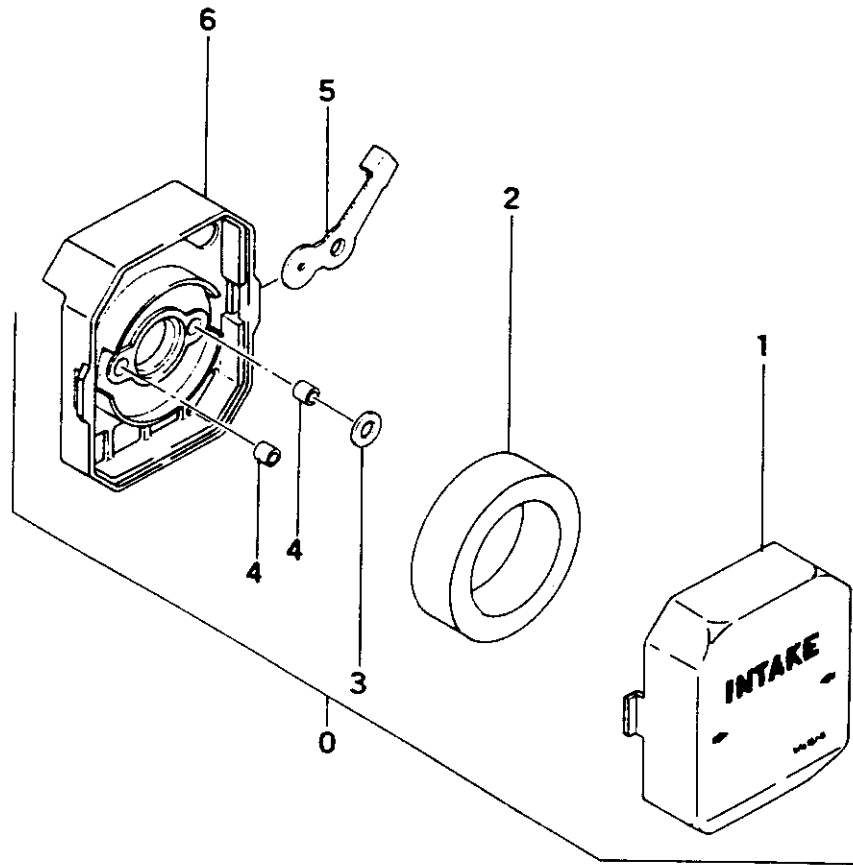

FIGURE 4

THT-200 PARTS LISTING

REF.	PART NO.	PART DESCRIPTION	Q	C	S	SERIAL NO.	REMARKS
0	410-0602D-901	CLEANER,AIR ASS'Y	1		A		
1	424-0602K-201	CAP,CLEANER	1		A		
2	446-0602K-200	ELEMENT,CLEANER	1		C		
3	453-0602K-200	COLLAR	1		C		
4	470-0602K-200	COLLAR	2		D		
5	528-0602D-200	PLATE,CHOKE,2MM	1		D		
6	423-0602K-000	SET,CLEANER BODY	1		D		

FIG.5 CARBURETOR

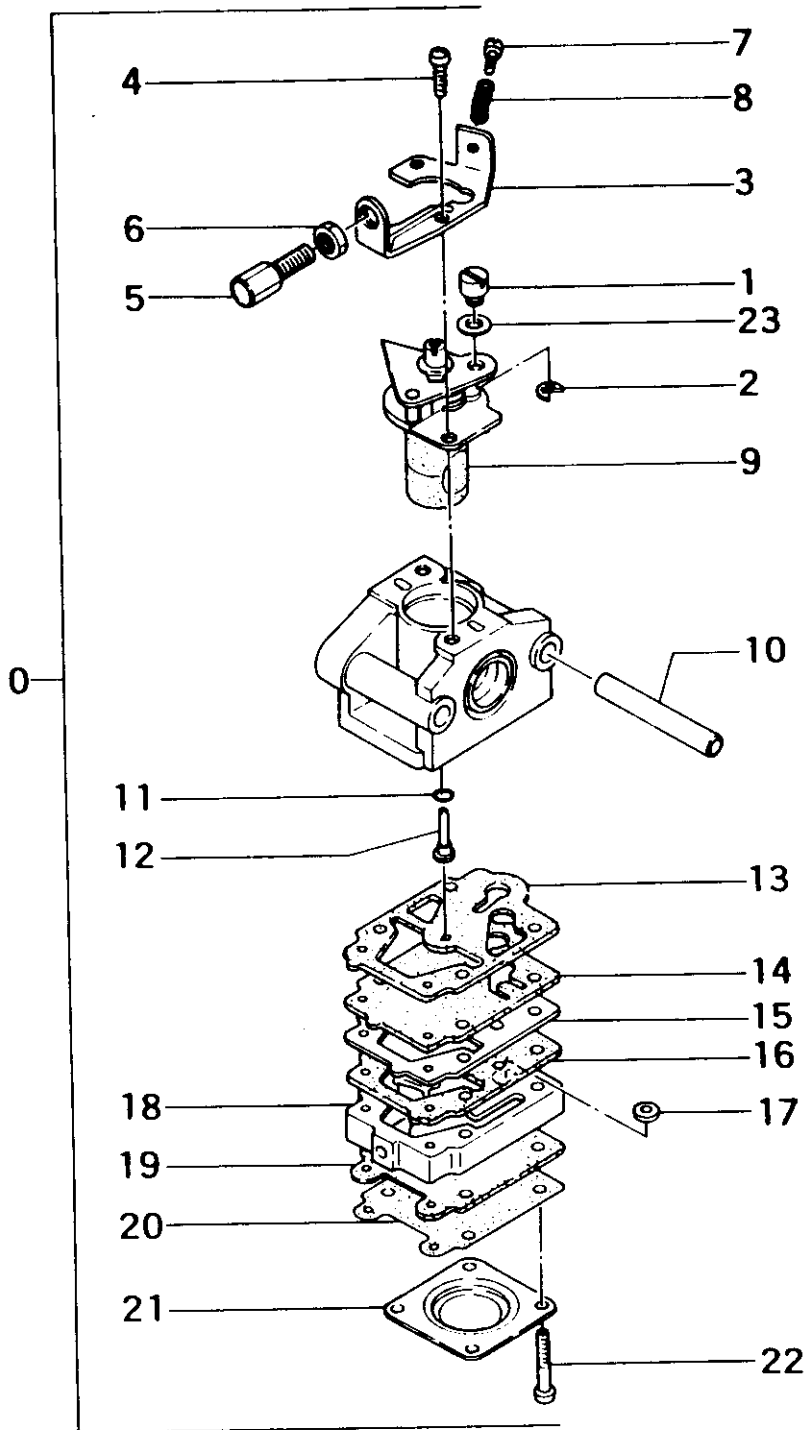

FIGURE 5

THT-200 PARTS LISTING

REF.	PART NO.	PART DESCRIPTION	Q	C	S	SERIAL NO	REMARKS
0	455-25103-903	CARBURETOR,ASS'Y	1		C		
1	539-25101-200	SWIVEL	1		D		
2	489-25100-200	RING,STOP	1		C		
3	544-25100-200	STAY,ADJUST	1		D		
4	514-25100-200	SCREW,THROTTLE SET	2		D		
5	894-01401-201	RECEIVER,OUTER	1		B		
6	991-01060-013	NUT,6	1		B		
7	462-25100-20	SCREW,IDLE ADJUST	1		D		
8	463-25100-200	SPRING,IDLE ADJUST	1		D		
9	488-25100-800	VALVE,THROTTLE	1		D	~G221000	
9	488-25106-800	VALVE,THROTTLE	1		D	G221001~	
10	437-25100-200	SLEEVE	2		D		
11	550-25100-200	O-RING	1		C		
12	599-2000W-520	JET,JET,#52	1		C	~G221000	
12	599-2000W-480	JET,MAIN,#48	1		D	G221001~	
13	~~~	*GASKET,PUMP	1		B		* Contained in Carb. Repair Kit 650-25100-910 (Not available individually)
14	~~~	*DIAPHRAGM,PUMP	1		B		
15	523-25100-201	PLATE,PUMP	1		C		
16	522-25100-200	PLATE,CIRCUIT	1		C		
17	~~~	*SCREEN,INLET	1		C		
18	575-25100-800	BODY,PUMP	1		D		
19	~~~	*GASKET,DIAPHRAGM	1		A		
20	~~~	*DIAPHRAGM,METERING	1		A		
21	476-25004-200	COVER,DIAPHRAGM	1		D		
22	548-25101-200	SCREW,SET	4		D		
23	549-25100-200	WASHER,THRUST	1		D		

* Indicates the part is included in a kit or assembly and is not available individually. Q=Quan. used
 C=Interchangeability S=Stocking code: A-Fast moving B=Med. fast C=Med. move D=Slow move
 E=N.L.A. F=Superseded or replaced by a new part

FIG.6 GEAR CASE & CUTTER

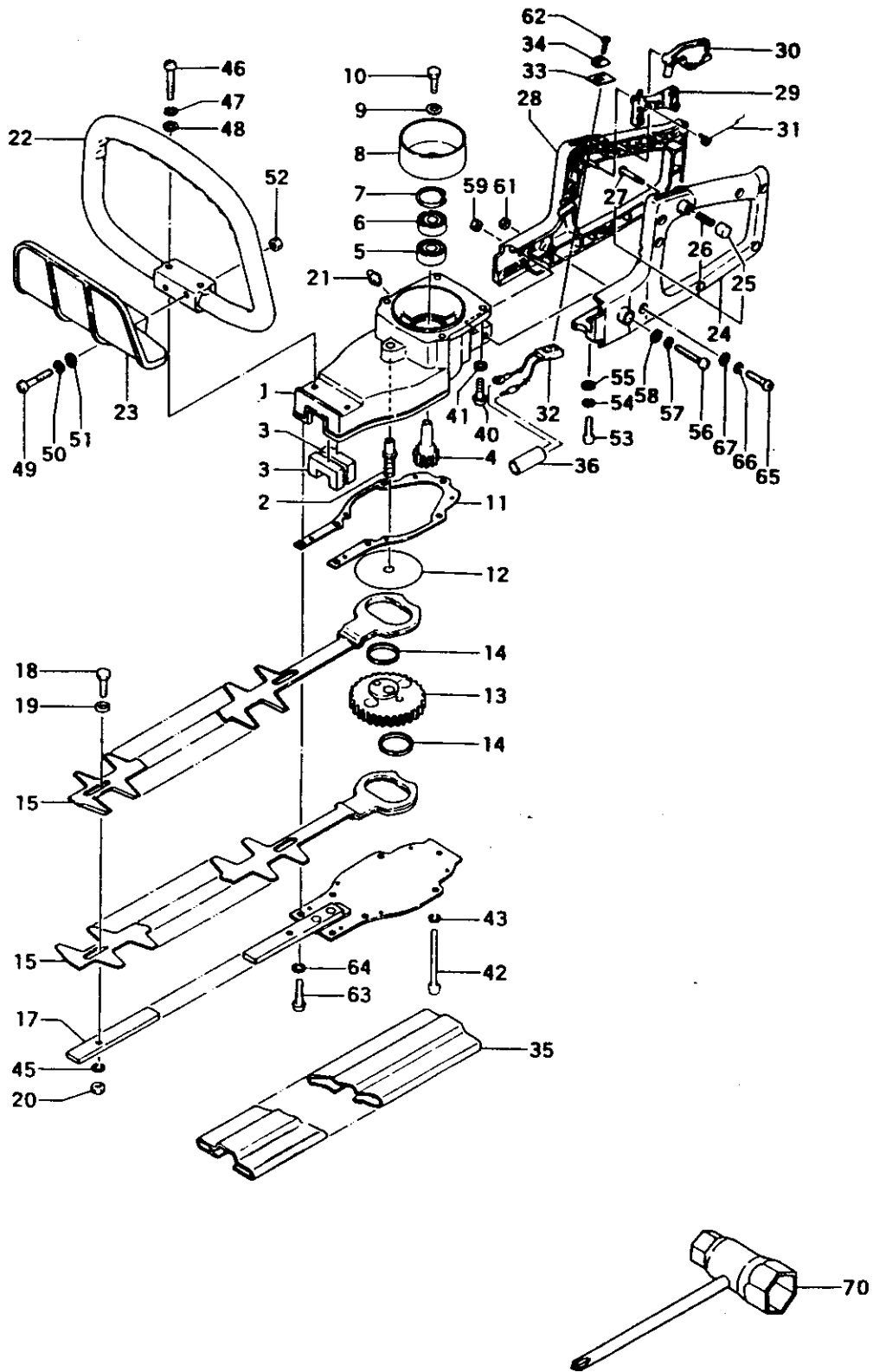

FIGURE 6

THT-200 PARTS LISTING

REF.	PART NO.	PART DESCRIPTION	Q	C	S	SERIAL NO	REMARKS
1	300-33150-201	CASE,GEAR	1		C		
2	305-33150-200	SHAFT,GEAR	1		D		
3	085-33150-200	SEAL,GREASE A	2		C		
4	306-33150-200	GEAR,1	1		D		
5	999-61600-000	BEARING,BALL,#6000	1		C		
6	999-61600-003	BEARING,BALL,#6000D	1		C		
7	993-51026-002	RING,STOP,IN,C-26	1		C		
8	288-0602W-822	DRUM,CLUTCH	1		B		
9	368-32350-200	WASHER,BRAKE SHAFT	1		C		
10	990-21050-106	BOLT,HT,5X10	1		C		
11	303-33150-200	GASKET,GEAR CASE	1		C		
12	075-33150-200	PLATE,GUIDE	1		D		
13	307-33150-200	GEAR,#2	1		D		
14	109-33150-200	RING,CAM	2		C		
15	CB-19A	BLADE,CUTTER,THT-200	2		A		
17	122-33150-800	GUIDE,CUTTER	1		B		
18	124-33202-206	BOLT,BLADE,A	4		A		
19	129-33202-201	WASHER,7	4		A		
20	123-33202-200	NUT,CUTTER FIXING	4		A		
21	200-33210-210	NIPPLE,GREASE	1		D		
22	210-33150-801	HANDLE	1		C		
23	052-33150-200	GUARD,HAND	1		D		
24	050-33150-801	HANDLE,A	1		D		
25	725-32600-202	CAP,PUSH PIN	1		C		
26	066-32300-201	SPRING,STOPPER	1		D		
27	064-32530-200	PIN,PUSH	1		C		
28	051-33150-201	HANDLE,B	1		D		
29	230-33150-200	LEVER,THROTTLE	1		D		
30	231-33150-200	LEVER,SAFETY	1		D		
31	232-33150-200	SPRING,THROTTLE LEVER	1		D		
32	170-0639W-800	BUTTON,STOP	1		D		
33	925-32530-200	DECAL,STOP BUTTON	1		C		
34	258-11650-20	BUTTON,STOP	1		C		
35	138-33151-200	COVER,CUTTER 19"	1		C		
36	279-11003-005	TUBE,PROTECTION	1		D		
40	990-11050-161	SCREW,5X16	2		B		
41	992-10050-012	WASHER,S,5	2		A		
42	990-11050-651	SCREW,5X65	2		A		
43	992-10050-012	WASHER,S,5	2		A		

* Indicates the part is included in a kit or assembly and is not available individually. Q=Quan. used
C=Interchangeability S=Stocking code: A-Fast moving B=Med. fast C=Med. move D=Slow move
E=N.L.A. F=Superseded or replaced by a new part

FIGURE 6 cont.

THT-200 PARTS LISTING

REF.	PART NO.	PART DESCRIPTION	Q	C	S	SERIAL NO	REMARKS
45	992-10060-012	WASHER,S,6	4		A		
46	990-11050-351	SCREW,5X35	2		B		
47	992-10050-012	WASHER,S,5	2		C		
48	992-01050-011	WASHER,5	2		A		
49	990-11050-351	SCREW,5X35	2		B		
50	992-10050-012	WASHER,S,5	2		A		
51	992-01050-011	WASHER,5	2		C		
52	991-78050-010	NUT,LOCK 5	2		C		
53	990-11060-181	SCREW,6X18	1		B		
54	992-10060-012	WASHER,S,6	1		A		
55	992-01060-011	WASHER,6	1		A		
56	990-11050-451	SCREW,5X45	1		C		
57	992-10050-012	WASHER,S,5	1		A		
58	992-00050-011	WASHER,SMALL,5	1		C		
59	991-78050-010	NUT,LOCK 5	1		C		
61	991-01040-011	NUT,4	7		C		
62	990-11030-101	SCREW,3X10	1		B		
63	990-11050-121	SCREW,5X12	5		A		
64	992-10050-012	WASHER,S,5	5		A		
65	990-11040-251	SCREW,4X25	7		C		
66	992-10040-012	WASHER,S,4	7		B		
67	992-00040-011	WASHER,4	7		B		
70	036-29331-501	SPANNER,COMBI	1		D		

* Indicates the part is included in a kit or assembly and is not available individually. Q=Quan. used
C=Interchangeability S=Stocking code: A-Fast moving B=Med. fast C=Med. move D=Slow move
E=N.L.A. F=Superseded or replaced by a new part

FIG.7 MARKS



FIGURE 7

THT-200 PARTS LISTING

REF.	PART NO.	PART DESCRIPTION	Q	C	S	SERIAL NO	REMARKS
1-2	906-0639W-201	DECAL	1		D		
1-3	950-37900-200	DECAL,PRO-FORCE A	1		C		
1	929-3210A-200	DECAL,INDUSTRIAL	1		C		
2	906-33150-200	DECAL,THT-200	1		D		
3	951-37900-200	DECAL,PRO-FORCE	1		D		